

High-quality recording of bioelectric events

Part 1 Interference reduction, theory and practice

A. C. Metting van Rijn A. Peper C. A. Grimbergen

Laboratory of Medical Physics, University of Amsterdam, Academic Medical Centre, Meibergdreef 15, 1105 AZ Amsterdam, The Netherlands

Abstract—In the first part of the review the various mechanisms that could be the cause of interference in bioelectric recordings are considered. It is demonstrated that the performance of a good amplifier can be seriously degraded in its functioning if the whole measurement situation is not taken into account. Several techniques used to reduce interference, of which guarding and driven right leg circuits are the most important, are analysed. In the second part of the review some examples of the application of the theory in practical situations are presented. The instrumentation amplifier circuit normally used in bioelectric recordings is improved for measurements under difficult circumstances. Another application is a low-cost 64-channel amplifier for multichannel ECG recordings. The third application is a device that can be added to bioelectric measurement systems and will provide a major reduction in interference.

Keywords—Bioelectric recordings, Driven right leg, Guarding, Interference, Isolation

Med. & Biol. Eng. & Comput., 1990, 28, 389–397

1 Introduction

BIOELECTRIC RECORDINGS are often disturbed by an excessive level of interference. Although its origin in nearly all cases is clear—the mains power supply—the cause of the disturbance is not at all obvious because in many cases very sophisticated equipment is used. Apparently, the use of equipment with very good specifications does not guarantee interference-free recordings. In this review it is argued that if a significant reduction in the level of interference is pursued, the whole measurement situation has to be analysed.

In most bioelectric measurements an interference level of 1–10 μV peak-to-peak (less than 1 per cent of the peak-to-peak value of an ECG) is acceptable. As the noise of a typical electrode is also several μV peak-to-peak (GEDDES and BAKER, 1966a; SPEKHORST *et al.*, 1988), in most circumstances 10 μV peak-to-peak can be accepted as the upper level of interference.

The most common mechanisms of electrical mains interference are described in the following sections.

2 Origin of interference

2.1 Interference currents through the body

The capacitances between the patient, the power lines and earth cause a small interference current to flow through the body (Fig. 1). In the modelling of the measurement situation the capacitance between the body and earth C_{body} is taken to be 300 pF and the capacitance between

the body and the mains power C_{pow} is taken to be 3 pF (HUHTA and WEBSTER, 1973; FORSTER, 1974), values which can be assumed to be typical. These capacitances cause an interference current (i_1 in Fig. 1) of c. 0.5 μA peak-to-peak to flow from the power supply lines (220 V RMS, 50 Hz) through the body to earth. It should be emphasised that C_{pow} and C_{body} show large variations and interference currents ten times as high as mentioned above are found regularly.

If an amplifier is connected to the patient, part of the current from mains to patient i_1 will flow to earth through Z_{rl} , the impedance of the electrode/skin interface of the 'neutral' electrode (the right leg electrode in standard ECG measurements). Measurements without the use of a neutral electrode are possible but are not treated here. The complications involved with these so-called two-electrode measurements are extensively treated elsewhere (THAKOR and WEBSTER, 1980). The portion of i_1 that flows through Z_{rl} causes a potential difference between the average potential of the body and the amplifier common: the common-mode voltage (V_{cm} in Fig. 1).

2.2 Interference currents into the amplifier

In a model of an isolated bioelectric measurement (i.e. no galvanic connection between the amplifier common and earth, switch open in Fig. 1) the capacitances between the amplifier common and mains C_{sup} and between amplifier common and earth C_{iso} should also be considered (Fig. 1). C_{sup} causes an additional interference current i_2 to flow from the amplifier to earth, partially via C_{iso} and partially via Z_{rl} and C_{body} . The portion of i_2 that flows through Z_{rl} contributes to the common-mode voltage.

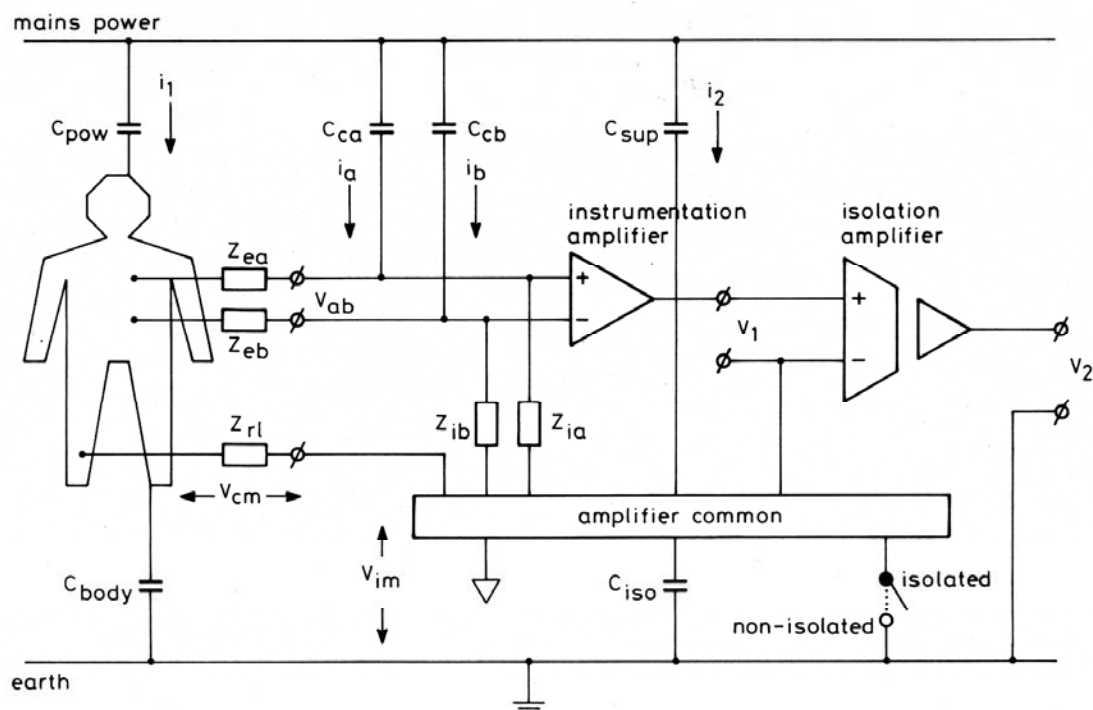

Fig. 1 Block diagram of a bioelectric measurement. The capacitances between the patient, the amplifier common and the measurement cables with respect to earth and mains cause interference currents i_1 , i_2 , i_a and i_b to flow. In a non-isolated situation the amplifier common is connected to earth (switch closed). The output voltage V_2 is recorded with respect to earth

2.3 Interference currents into the measurement cables

A major source of interference in bioelectric measurements results from the capacitive coupling of the measurement cables with the mains (C_{ca} and C_{cb} in Fig. 1). The currents induced in the wires (i_a , i_b in Fig. 1) flow to the body via the electrodes and from the body to earth via C_{body} and via Z_{rl} in series with C_{iso} . Because both the currents induced in the wires and the electrode impedances generally differ significantly, a relatively large differential voltage is produced between the amplifier inputs (V_{ab} in Fig. 1). The magnitude of this voltage is given by the following relationship:

$$V_{ab} = i_a Z_{ea} - i_b Z_{eb} = i Z_e \left(\frac{\Delta Z_e}{Z_e} + \frac{\Delta i}{i} \right) \quad (1)$$

where $i = 1/2(i_a + i_b)$ $Z_e = 1/2(Z_{ea} + Z_{eb})$

A typical situation with a mean current of 10 nA peak-to-peak in the wires, a mean electrode impedance of 20 k Ω and a relative difference in interference current and electrode impedance of 50 per cent leads to an unacceptably high interference level of 200 μ V peak-to-peak.

2.4 Magnetically induced interference

Magnetically induced interference is easily distinguished from other types of interference because it varies with the area and orientation of the loop formed by the measurement cables. Suppression is easy in theory by reducing this area as much as possible (twisting of cables) (HUHTA and WEBSTER, 1973). In practice, this is not always feasible. For example: the usual electrode configuration in ECG measurements with electrodes placed at the extremities of the body might cause a considerable area between the input cables. Shielding of the patient with a material with a high magnetic permeability (μ -metal) is an impractical solution in most situations. Therefore it is often necessary to lower the magnetic field itself by shielding the sources of magnetic fields with multiple layers of μ -metal interleaved with heavy copper layers (MOTCHENBACHER and FITCHEN, 1972) and/or by keeping all magnetic sources far from the patient.

3 Interference reduction

3.1 Influence of common-mode voltage

There are two ways by which a high common-mode voltage may cause interference. The first, obvious way is when the common-mode rejection ratio of the amplifier is limited. This mechanism is not often problematic with modern differential amplifiers: a common-mode rejection ratio of 80–90 dB is customary. A second, and much more important way a high-common mode voltage may cause interference is when there are differences in electrode impedances and/or input impedances which convert common-mode voltage into a differential input voltage (Fig. 1). This mechanism, often called 'the potential divider effect' (HUHTA and WEBSTER, 1973; PACELA, 1967), is the main reason why it is important to reduce the common-mode voltage as much as possible. The magnitude of the differential interference input voltage generated this way is given by the following relationship (see Fig. 1):

$$V_{ab} = V_{cm} \left\{ \frac{Z_{ia}}{Z_{ia} + Z_{ea}} - \frac{Z_{ib}}{Z_{ib} + Z_{eb}} \right\} \quad (2)$$

where $Z_{ia, b}$ are input impedances
 $Z_{ea, b}$ are electrode impedances

It is instructive to rewrite this equation assuming the input impedances to be much larger than the electrode impedances:

$$V_{ab} = V_{cm} \frac{Z_e}{Z_i} \left\{ \frac{\Delta Z_e}{Z_e} + \frac{\Delta Z_i}{Z_i} \right\} \quad (3)$$

where $Z_e = 1/2(Z_{ea} + Z_{eb})$ $Z_i = 1/2(Z_{ia} + Z_{ib})$

It appears that the level of interference generated by the potential divider effect depends on the magnitude of the common-mode voltage, the ratio of the average electrode and input impedances, and on the relative differences in electrode and input impedances.

The usual electrodes may show a mean impedance of 20 k Ω at 50 Hz and impedance differences of c. 50 per cent (ALMASI and SMITT, 1970; GRIMNES, 1983; GEDDES, 1972). Differences in input impedances should not exist in a care-

fully designed amplifier system, but often these differences are not easy to avoid. Differences in input impedances are often found in multichannel measuring systems (an example is given in Section 4.2.) but may also be caused by the use of shielded input cables of different length.

3.2 Reduction of the common-mode voltage

If the impedance differences of electrodes and inputs cannot be kept sufficiently low to reduce the influence of the potential divider effect, the input impedances being as high as possible, the only practical solution left is to reduce the actual common-mode voltage. There are three situations:

- The amplifier common is connected to earth (Fig. 1, switch closed: no isolation): the amount of interference current through Z_{rl} is determined mainly by the capacitance C_{pow} . Consequently, the common-mode voltage is reduced if this capacitance between body and mains is minimised.
- The amplifier common is not connected to earth (Fig. 1, switch open: isolation): the resulting current through Z_{rl} depends on the values of the four capacitances C_{pow} , C_{body} , C_{sup} and C_{iso} . In this situation, the common-mode voltage might be reduced by minimising the capacitance between the amplifier common and mains (C_{sup}) and the capacitance between the amplifier common and earth (C_{iso}).
- In all cases, the common-mode voltage can be largely reduced if a driven right leg circuit is added (Fig. 2). An extra amplifier drives the patient to the same voltage as the voltage of the amplifier common. The voltage difference between patient and amplifier common (=common-mode voltage) can be made much smaller this way than the voltage across Z_{rl} in Fig. 2.

With the first method, rather low common-mode voltages are possible if the impedance Z_{rl} is low (good electrode and extensive preparation of the skin) and the capacitance C_{pow} is small (all power lines and mains powered devices far from the patient). In a typical situation ($C_{pow} = 3$ pF, $Z_{rl} = 20$ k Ω) the common-mode voltage is an acceptable 10 mV peak-to-peak. In this case, a mean $Z_i = 20$ M Ω , a mean $Z_e = 20$ k Ω and relative differences in Z_e and Z_i of 50 per cent results in an interference voltage of 10 μ V

peak-to-peak (see eqn. 3). However, in clinical situations this method is not used because the low-impedance path that is formed between body and earth brings the patient into a potentially unsafe situation (OLSON, 1978).

An isolated measurement is very safe if the capacitance between the amplifier common and earth C_{iso} and the capacitance between the amplifier common and mains C_{sup} are kept sufficiently small. However, the magnitude of the common-mode voltage is only then significantly lower than in the first situation, if C_{sup} is much smaller than C_{pow} and C_{iso} is much smaller than C_{body} . Two numerical examples will provide some clarification.

Consider a good isolation amplifier with a relatively small capacitance of the isolation barrier of 30 pF ($C_{iso} = 30$ pF). If the amplifier is small and battery powered the capacitance to the mains power supply can be neglected ($C_{sup} < 1$ pF). It can be calculated that under typical conditions ($C_{body} = 300$ pF, $C_{pow} = 3$ pF, $Z_{rl} = 20$ k Ω), the common-mode voltage will be small, approximately 1 mV peak-to-peak.

A different situation is encountered with a multichannel measurement system in which isolation is achieved with an isolated power supply. In this case C_{sup} and C_{iso} can both be as high as 100 pF and a large common-mode voltage of approximately 200 mV peak-to-peak would be generated under typical conditions. Note that the leakage current does not exceed the safety regulations (< 10 μ A RMS), even if the patient touches earth or mains. An example of a measurement system with relatively large capacitances to mains and earth is given in Section 4.2.

Isolated measurements can be problematic, even if the common-mode voltage is kept small, when the interference voltage across the isolation (isolation mode voltage, V_{im} in Fig. 1) is not rejected sufficiently (PALLAS-ARÉNY, 1988). Inspection of Fig. 1 shows that the isolation mode voltage can be large in typical situations (for the two examples mentioned above respectively 6 V peak-to-peak and 120 V peak-to-peak). Consequently, a very high isolation-mode rejection ratio (120–150 dB) is essential in an isolated bioelectric recording. A high isolation mode rejection ratio can be achieved with modern photo-optical isolation techniques (analogue or digital) combined with a high gain front-end (thus reducing the difference in magnitude between the amplified bioelectric signal that is transmitted across the isolation barrier and the large isolation mode voltage).

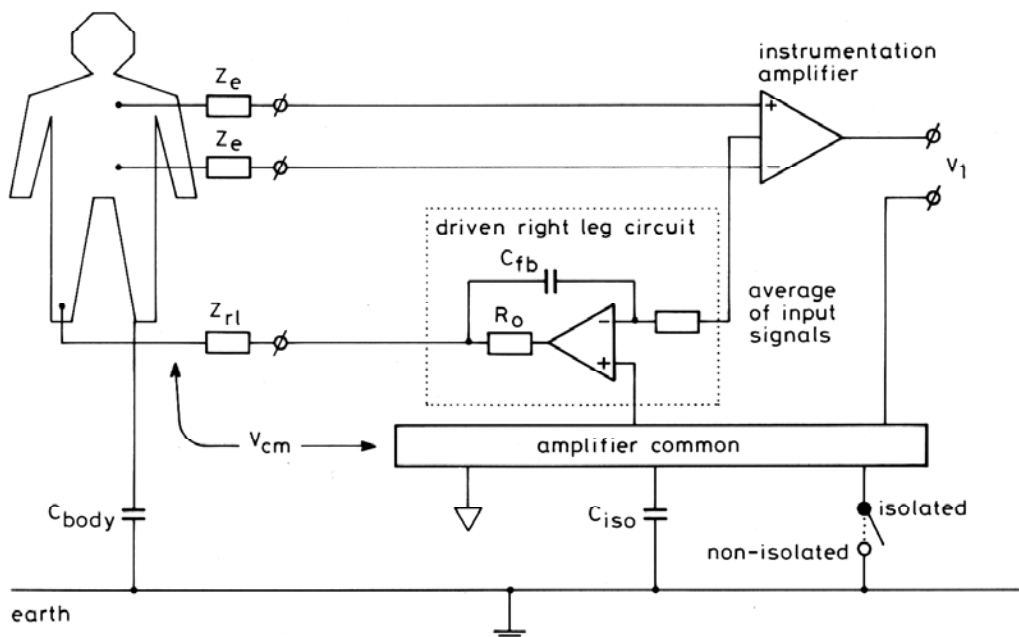

Fig. 2 Driven right leg circuit. If the gain of the driven right leg circuit is high, the common-mode voltage V_{cm} is much smaller than the voltage across Z_{rl}

A proper driven right leg circuit (Fig. 2) offers a large reduction of common-mode voltage magnitude in both isolated and non-isolated measurements by actively reducing the voltage difference between patient and amplifier common; a reduction between 10 and 50 dB is usually accomplished. A driven right leg circuit is the most practical way to reduce the common-mode voltage if a reduction of interference current through Z_{r1} is not feasible. In addition, the driven right leg circuit makes measurements reasonably safe in a non-isolated situation (switch closed in Figs. 1 and 2) because a rather large impedance between body and earth can be achieved by selecting a large resistor R_0 (several M Ω) and a small feedback capacitor C_{fb} (<1 nF). This feature can be used to omit isolation amplifiers in experimental situations in which safety standards are not as critical as in clinical situations. The main drawback of a driven right leg circuit is it being potentially unstable (WINTER and WEBSTER, 1983). In practical designs, a compromise between common-mode suppression and possible instability, depending on circumstances, must be found. This problem is worked out in more detail in the Appendix.

3.3 Reduction of interference currents in the measurement cables

Given the inherent variability of the electrode impedances and the level of interference in recordings (eqn. 1), there is only one practical way to reduce interference currents in the wires: shielding the measuring cables. The different possible shielding techniques are treated below.

3.3.1 Shields connected to amplifier common. Simply connecting the shields to the amplifier eliminates interference currents in the wires. However, it usually does not reduce the total level of interference. The high capacitance of shielded input cables reduces the input impedance of the amplifier resulting in an increase of the level of interference because of the potential divider effect (eqn. 3). The common-mode signal, which is the cause of this form of interference, cannot effectively be reduced with a driven right leg circuit because the increased input capacitance of the amplifier easily results in instability of the circuit (see Appendix).

3.3.2 Guarding. When a shield is driven with the signal at the inner wire, there is virtually no cable capacitance and its contribution to the input impedance of the circuit is negligible (MORRISON, 1977). This technique is usually known as guarding. A consequence is that for each input an extra amplifier is needed to drive the shield.

3.3.3 Guarding with the average of the input signals. If all shields are driven with the average of the input signals (=common-mode voltage), the input capacitance for common-mode signals is vanishingly small because there exists no potential difference between shield and inner wire to create signals. Hence, there is no extra sensitivity to interference signals caused by the potential divider effect. Stability problems of an effective driven right leg circuit can be avoided with a careful design of the guarding circuit (see Appendix).

This method is a good compromise between the other two shielding techniques: good interference suppression is achieved with just one extra amplifier. A drawback is that the input capacitance for differential signals is just as low as in the situation with the shields connected to the amplifier common because for differential mode signals the voltage difference between shield and inner core is not reduced by the guarding circuit. The resultant low input impedance for differential mode signals at high frequencies may lead to signal loss and distortion (GEDDES and BAKER, 1966b). However, in normal ECG and EEG recordings which have a restricted frequency content (<200 Hz), the extra input capacitance for differential mode signals is not problematic if extremely long measuring cables are avoided.

4 Applications

4.1 An improved instrumentation amplifier

The three-operational amplifier instrumentation amplifier shown in the inlay of Fig. 3 is generally used as input stage in bioelectric measurements. Its input impedance is high and a good common-mode rejection ratio can be obtained without extensive trimming (TOBEY *et al.*, 1971). Parameters such as noise, bandwidth, input bias current and power consumption can easily be controlled if the right operational amplifiers are chosen. A three-

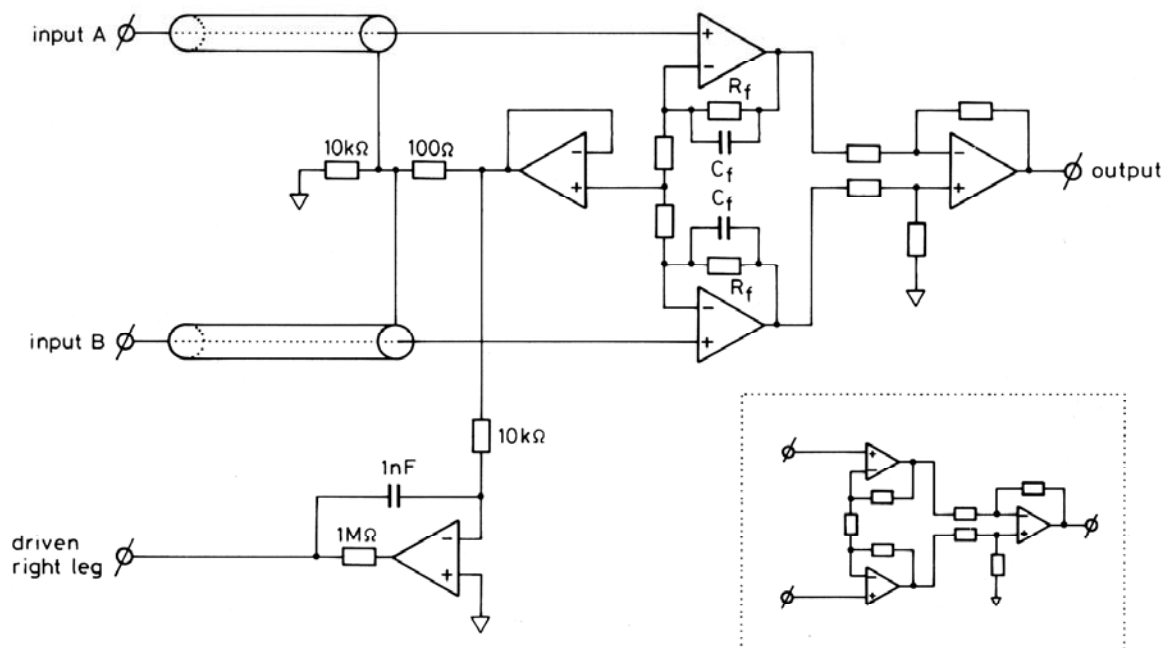

Fig. 3 Biomedical instrumentation amplifier equipped with guarding and driven right leg circuits, based on the three operational amplifier instrumentation amplifier (see inlay)

operational amplifier instrumentation amplifier was equipped with provisions for a driven right leg and driven shields. The complete circuit is shown in Fig. 3. Some details will now be discussed.

4.1.1 Guarding circuit. Both shields are driven by the same buffer amplifier. This buffer should have a gain of unity from DC up to a few MHz in order to assure stable operation of the complete amplifier (see Appendix). Some operational amplifiers used in a buffer configuration have a gain larger than unity at high frequencies. Proper compensation should be provided in these cases because of possible instability.

The input signal for the shield driver should be the average of the input signals. A good approximation of this signal is the average of the inverting inputs. To compensate for the capacitance of the inverting input of the input-operational amplifier, small capacitors C_f with a value equal to the input capacitance must be added (Fig. 3 and Appendix).

The gain of the shield driver has been put to 0.99. This reduces the signal magnitude at the shield to 99 per cent of the average signal magnitude at the inner wires, thereby improving the stability of the guarding circuit and reducing the peaking in the frequency response, while there remains a considerable reduction of the effective cable capacitance (a factor of 100) (MORRISON, 1977).

4.1.2 Driven right leg circuit. The input signal for the driven right leg circuit should be the average of the input (= common-mode voltage). The output signal of the shield drive buffer differs very little from this average signal for reasons described above, and can be used for this purpose.

The open-loop gain of the driven right leg circuit is 300 at 50 Hz, resulting in a 50 dB increase in common-mode rejection at this frequency. This proved to be a good compromise between maximum common-mode reduction and stability requirements (see Appendix).

For reasons of simplicity, the low frequency roll-off is not shown in the circuit of Fig. 3. In practical use the amplifier should have a low gain for DC signals to prevent saturation caused by electrode offset voltages to occur. There are several solutions for DC suppression (HAMSTRA *et al.*, 1984; MCCLELLAN, 1981).

4.2 Low-cost 64-channel ECG amplifier

In this section it will be demonstrated how an amplifier design can be improved to acceptable standards without altering the complete layout. In the case taken as an example, a low-cost 64-channel ECG amplifier for multi-channel recording, there were good reasons, most important being cost and size, to hold on to an amplifier setup which was not optimal in some respects.

The initial situation was:

- The input stage was formed by 64 separate instrumentation monolithic instrumentation amplifiers which made the design compact and fairly cheap (SMIT *et al.*, 1987).
- Each instrumentation amplifier measured the potential difference between a chest electrode and a reference signal. The reference signal was the average of the signals from the arms and the left leg (Wilson central terminal), obtained by passive summation with three resistors (300 k Ω). This led to a configuration in which the Wilson central terminal was connected to 64 (inverting) amplifier inputs.

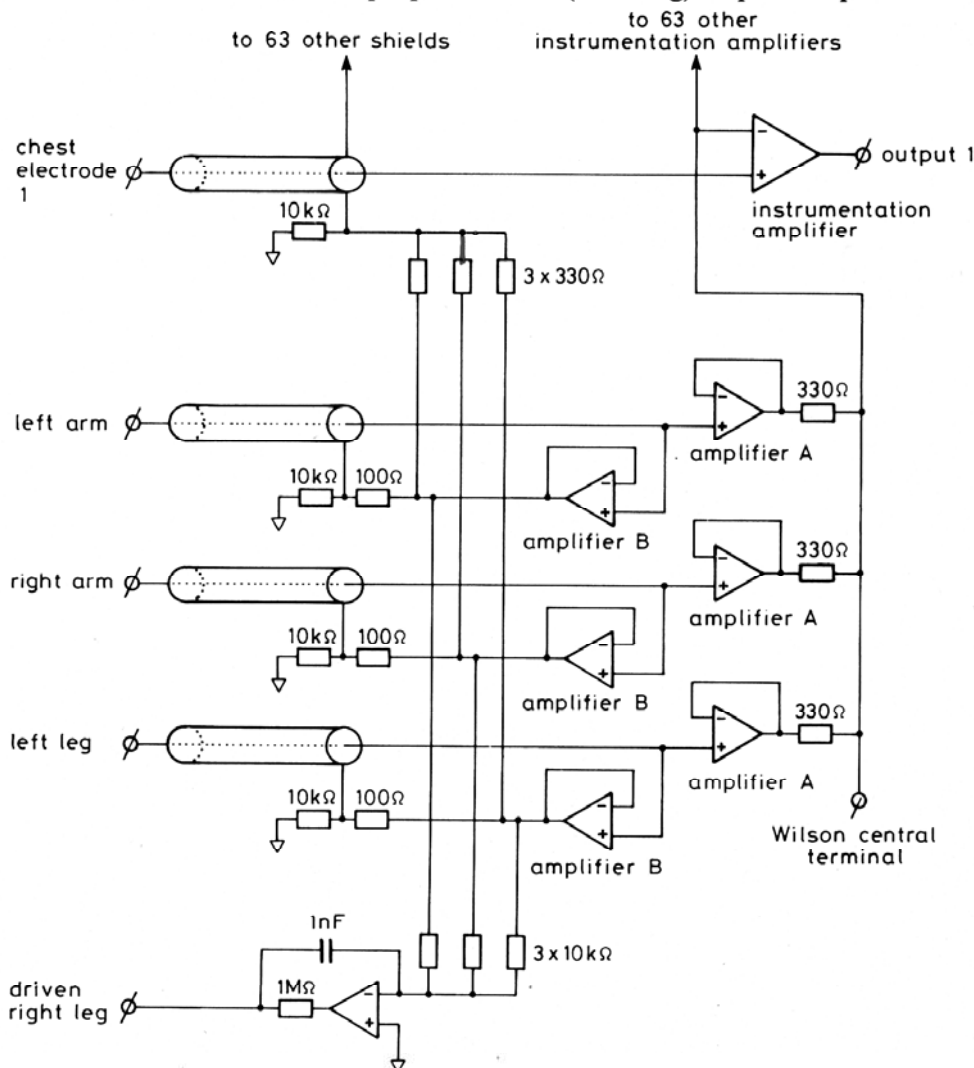

Fig. 4 Reference (Wilson central terminal), guarding and driven right leg circuits for a 64-channel ECG amplifier

(c) Isolation was necessary because of safety. However, because 64 isolation amplifiers would make the system too expensive, isolation was accomplished with a medical isolation transformer in the power supply.

These aspects presented some intrinsic interference problems. The interference current flowing from the mains supply to the amplifier common (C_{sup} and C_{iso} were in the order of 100 pF, see Sections 2.3 and 3.1) resulted in a common-mode signal of approximately 200 mV peak-to-peak. The rejection of this large common-mode signal was poor because of the large differences in input impedances. The input impedance of the reference lead was very low compared with the input impedance of the 64 chest lead inputs because of the interconnection of 64 inverting inputs and the low impedance of the Wilson central terminal.

Good results were achieved with the extra input circuit shown in Fig. 4. The inclusion of this circuit results in a system where all inputs have a very high impedance and the impedance differences are small. All electrode leads are equipped with guarding. Two buffers are used for the arm and left leg signals; an operational amplifier with a superior noise figure is used for impedance transformation of the actual input signal (amplifier A) and another operational amplifier with a high input impedance, a high gain bandwidth product and a stable high-frequency performance is used as a shield driver (amplifier B).

It should be emphasised that the performance of the complete 64-channel amplifier is entirely determined by this input circuit. The equivalent input noise is primarily the noise of the buffer amplifiers and the resultant common mode rejection ratio depends on the driven right leg circuit gain, the input impedance of the buffer amplifiers and the accuracy of the buffer amplifiers having unity gain. The specifications of the used instrumentation amplifier, which are exceptionally good by any standard, have only a small influence on the overall specifications.

Several recording systems equipped with this 64-channel amplifier are now regularly in use in a body surface mapping research project (REEK *et al.*, 1984).

4.3 Add-on device for a recording system

If the performance of a recording system is poor and the development of a complete new amplifier system cannot be considered, use can be made of the circuit shown in Fig. 5. This circuit can be added to any amplifier. It suppresses common-mode voltage effectively and it provides guarding of the measurement cables without deteriorating the performance of the existing amplifier. The extra input capacitance and bias current can be neglected when high-quality JFET operational amplifiers are used. The circuit can be extended to any number of channels. The device is in use for the recording of surface His-bundle potentials (PEPER *et al.*, 1985), where very small signals (some microvolts) have to be recorded and a low level of noise and interference is of utmost importance.

5 Discussion

In this review it is demonstrated that considerable improvement can be obtained in the susceptibility of amplifier systems to interference. Shielding combined with guarding techniques to prevent interference currents in the measurement cables appeared to be of most importance in this respect. Regrettably most of the commercially available electrode systems do not provide standard shielded leads.

Common-mode voltage reduction remains important because differences in electrode impedance cause differential mode interference, even if the impedances of the amplifier inputs are equal. Although good preparation of the electrodes and the skin may reduce this type of interference, electrode impedances differ with every new recording and are inherently an uncertain factor. Some reduction

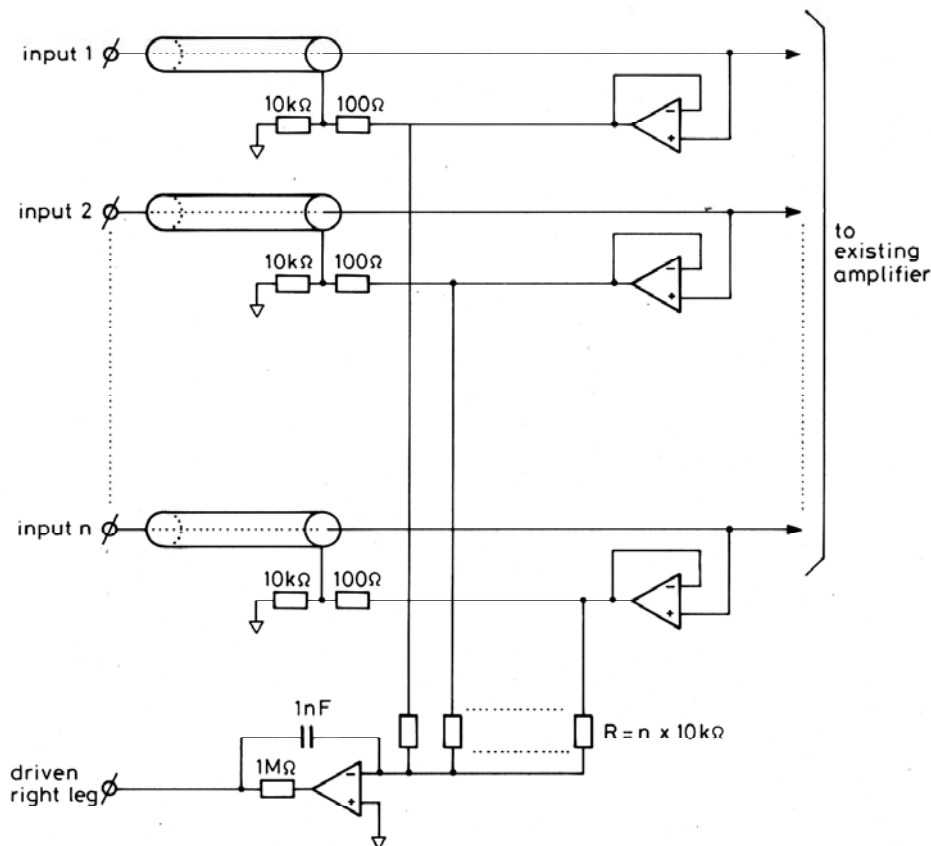

Fig. 5 Add-on circuit for an n -channel bioelectric measurement. The circuit reduces the common-mode voltage (driven right leg circuit) and interference currents in the measurement cables (guarding)

of the common-mode voltage can be obtained by a good isolation of the amplifier circuit, i.e. the capacitances of the amplifier to mains and earth should be much smaller than the capacitances of the body to mains and earth. However, these low capacitances are usually not easy to achieve and isolation must therefore be regarded mainly as a way to improve patient safety. More effective common-mode voltage reduction can be obtained with a driven right leg circuit.

The combination of guarding and driven right leg circuits has been given special attention. Both circuits form feedback loops and it is shown in the Appendix that careful dimensioning of each circuit is important to accomplish a stable combination. The applications presented in this study are designed to be stable even when the impedances in the measurement situation (electrode impedances, body and amplifier capacitance etc.) differ largely from the values encountered in a typical situation. Consequently, the performance of these circuits can be improved in many measurement situations. A good solution to this problem might be an optimisation of the guarding and driven right leg circuits—dependent on the measurement situation—by an automated procedure with a digital signal-processing system.

A special class of interference is the high-frequency interference caused by, for instance, fluorescent tubes or switching power supplies. Common-mode voltage reduction is less effective at higher frequencies because the driven right leg circuit gain decreases with frequency. Moreover, at high frequencies the input impedance of an amplifier will decrease because of its capacitive component, increasing the effect of the common-mode interference voltage. Although high frequencies are usually filtered out in bioelectric measurements, amplifiers can easily saturate or produce low-frequency distortion components. High-frequency interference therefore remains a factor of great concern which in some situations may render high-quality recordings impossible.

Acknowledgment—This research was supported by the Dutch Technology Foundation (STW).

References

- ALMASI, J. J. and SMITT, O. H. (1970) Systemic and random variations of ECG electrode impedance. *Ann. NY Acad. Sci.*, **170**, 509–519.
- FORSTER, I. C. (1974) Measurement of patient body capacitance and a method of patient isolation in mains environments. *Med. & Biol. Eng.*, **12**, 730–732.
- GEDDES, L. A. and BAKER, L. E. (1966a) Chlorided silver electrodes. *Med. Res. Eng.*, **6**, 33–34.
- GEDDES, L. A. and BAKER, L. E. (1966b) The relationship between input impedance and electrode area in recording the ECG. *Med. & Biol. Eng.*, **4**, 439–450.
- GEDDES, L. A. (1972) *Electrodes and the measurements of bioelectric events*. Wiley Interscience, New York, 44–94.
- GRIMNES, S. (1983) Impedance measurements of individual skin surface electrodes. *Med. & Biol. Eng. & Comput.*, **21**, 750–755.
- HAMSTRA, G. H., PEPPER, A. and GRIMBERGEN, C. A. (1984) Low-power, low-noise instrumentation amplifier for physiological signals. *Ibid.*, **22**, 272–274.
- HUHTA, J. C. and WEBSTER, J. G. (1973) 60-Hz interference in electro-cardiography. *IEEE Trans.*, **BME-20**, 91–101.
- MCCLELLAN, A. D. (1981) Extracellular amplifier with bootstrapped input stage results in high common-mode rejection. *Med. & Biol. Eng. & Comput.*, **19**, 657–658.
- MORRISON, R. (1977) *Grounding and shielding techniques in instrumentation*, 2nd edn. John Wiley & Sons, New York, 132–133.
- MOTCHENBACHER, C. D. and FITCHEN, F. C. (1972) *Low-noise electronic design*. John Wiley & Sons, New York, 185–187.

- OLSON, W. H. (1978) Electrical safety. In *Medical instrumentation: application and design*. WEBSTER, J. G. (Ed.), Houghton Mifflin Co., Boston, 667–706.
- PACELA, A. F. (1967) Collecting the body's signals. *Electronics*, **40**, 103–112.
- PALLAS-ARÉNY, R. (1988) Interference-rejection characteristics of biopotential amplifiers: a comparative analysis. *IEEE Trans.*, **BME-35**, 953–959.
- PEPPER, A., JONGES, R., LOSEKOOT, T. G. and GRIMBERGEN, C. A. (1985) Recording of surface His-Purkinje potentials. *Med. & Biol. Eng. & Comput.*, **23**, 365–376.
- REEK, E. J., GRIMBERGEN, C. A. and VAN OOSTEROM, A. (1984) A low-cost 64 channel microcomputer based data acquisition system for bedside registration of body surface maps. Proc. 11th Int. Congr. Electrocardiol., Caen, France, 17th–20th July, 37–38.
- SMIT, H. W., VERTON, K. and GRIMBERGEN, C. A. (1987) A low-cost multichannel preamplifier for physiological signals. *IEEE Trans.* **BME-34**, 307–310.
- SPEKHORST, H., SIPPENS-GROENEWEGEN, A., DAVID, G. K., METTING VAN RIJN, A. C. and BROEKHUYSEN, P. (1988) Radio-transparent carbon fibre electrode for ECG recordings in the catheterization laboratory. *Ibid.*, **BME-35**, 402–406.
- THAKOR, N. V. and WEBSTER, J. G. (1980) Ground-free ECG recording with two electrodes. *Ibid.*, **BME-27**, 699–704.
- TOBEY, G. E., GRAEME, J. G. and HUELSMAN, L. P. (1971) *Operational amplifiers: design and applications*. McGraw-Hill, New York, 206–207.
- WINTER, B. B. and WEBSTER, J. G. (1983) Driven-right-leg circuit design. *IEEE Trans.*, **BME-30**, 62–66.

Appendix

Instability of combined driven right leg and guarding circuits

An amplifier system equipped with a guarding or driven right leg circuit is liable to instability. Both driven right leg and guarding circuits are feedback circuits, and combining them may give rise to complications. In this Appendix, the stability of a bio-medical amplifier equipped with guarding only is considered first. Next, the combination of a guarding circuit with an optimal driven right leg circuit is treated.

Guarding

When the input cables are equipped with a driven shield a feedback loop results (Fig. 6). The loop is formed by the input

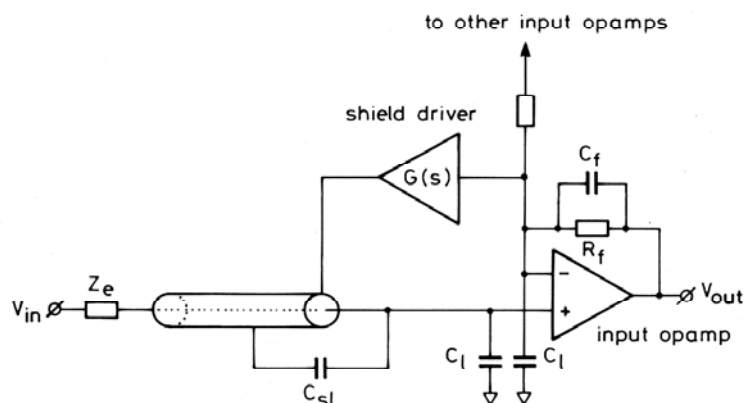

Fig. 6 The feedback loop formed by a guarding circuit. The loop is closed by the capacitance between the shield and the inner core C_{sl} . The operational amplifier is the input stage of an instrumentation amplifier

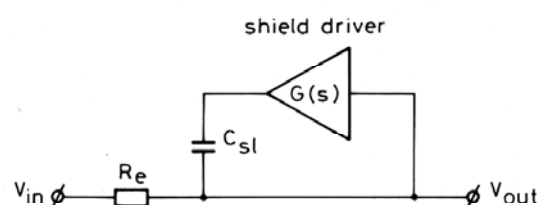

Fig. 7 Simplified diagram of the guarding circuit shown in Fig. 6

operational amplifier, the shield driver and the capacitance between the shield and the inner core of the input cable (C_{si} in Fig. 6). A simplified diagram is given in Fig. 7. The difference between the signals at the inverting and non-inverting input of the operational amplifier is assumed to be negligible up to a very high frequency, the input capacitances are omitted and the electrode impedance is treated as a resistance. Note that a circuit with positive feedback is formed. The (closed-loop) transfer function of the simplified circuit in Fig. 7 is given by

$$H(s) = \frac{V_{out}}{V_{in}} = \frac{1}{1 + \tau_1(1 - G(s))s} \quad (4)$$

where $G(s)$ is the frequency response of the shield driver and time constant τ_1 is $R_e C_{si}$.

A stable circuit can be achieved if the shield driver has a first-order response

$$G(s) = \frac{A}{1 + \tau_2 s} \quad (5)$$

where A is a constant

Substitution results in a second-order response of the guarding circuit in Fig. 7:

$$H(s) = \frac{1 + \tau_2 s}{1 + \{\tau_2 + (1 - A)\tau_1\}s + \tau_1\tau_2 s^2} \quad (6)$$

This second-order response has its resonance frequency at approximately

$$f_{res} = \frac{2\pi}{\sqrt{(\tau_1\tau_2)}} \quad \text{if } \tau_1 \gg \tau_2 \text{ and } A = 1 \quad (7)$$

The quality factor Q is then

$$Q = \frac{\sqrt{(\tau_1\tau_2)}}{\tau_2 + (1 - A)\tau_1} = \sqrt{(\tau_1/\tau_2)} \quad \text{if } A = 1 \quad (8)$$

The circuit is stable only if its poles are situated in the left half of the complex s -plane. This requirement results in the following condition:

$$A < 1 + \tau_1/\tau_2 \quad (9)$$

The equations above demonstrate that a guarding circuit which eliminates the cable capacitance up to a high frequency and which has a maximally flat frequency response $H(s)$ (eqn. 6) can be obtained with the right choice of A and τ_2 . From eqns. 4, 5 and 6 it can be concluded that the input capacitance related to the shield is negligible at frequencies much lower than $1/(2\pi\tau_2)$ if A is taken equal to 1. However, with A equal to 1, the circuit Q (eqn. 8) will be larger than $1/\sqrt{2}$ if τ_2 is chosen smaller than $2\tau_1$, and consequently the response $H(s)$ (eqn. 6) will show peaking at a frequency given by eqn. 7. On the other hand, if τ_2 is chosen larger than $2\tau_1$ the effectiveness of the guarding circuit is limited to low frequencies. A guarding circuit with τ_2 about equal to $2\tau_1$ offers the best compromise. It follows from eqn. 9 that a guarding circuit with A equal to 1 and τ_2 equal to $2\tau_1$ is stable.

In practice, it is not possible to choose an exact ratio between τ_2 and τ_1 because τ_1 depends on the cable capacitance and the electrode impedance and varies with each measurement. Furthermore, electrode impedances may show large variations at high frequencies. However, a τ_2 between 2×10^{-5} and 2×10^{-6} s proved to be a good choice in most measurement situations (a low-pass cut-off frequency of the shield driver between 10 kHz and 100 kHz).

If a guarding circuit is to be used in combination with a driven right leg circuit, not only is the amplitude response of importance, but the phase shift should also be taken into account. It will be shown in the next section that a guarding circuit with a low-pass cutoff frequency of the shield driver between 10 kHz and 100 kHz produces a considerable additional phase shift in the driven right leg circuit which can lead to instability. It will be shown also that the additional phase shift caused by the guarding circuit is not significant as long as the low-pass cut off frequency of the guard driver is chosen higher than approximately 1 MHz. A low-pass cutoff frequency of 1 MHz ($\tau_2 = 2 \times 10^{-7}$ s) results in a circuit Q (eqn. 8) of 2–10, resulting in a peak in the frequency response of up to 20 dB. Some peaking in the frequency response of the guarding circuit is acceptable because the following instrumentation amplifier is usually equipped with a low-pass filter. Furthermore, the circuit Q can be decreased by taking A little smaller than 1 (see eqn. 8) at the cost of a less effective reduction of cable capacitance. A gain A smaller than 1 also ensures a stable circuit independent of the actual values of τ_1 and τ_2 (eqn. 9).

Good results were obtained with a shield driver consisting of a voltage follower and an attenuator (to achieve an A of 0.99). The voltage follower was built with a relatively fast operational amplifier with a stable high-frequency performance (TL084, GBP = 3 MHz) in a buffer configuration. This guarding circuit was used in the applications shown in Figs. 3–5. In a typical measurement situation this circuit decreases the effective cable capacitance by 99 per cent up to a frequency of approximately 100 kHz while the peak in the frequency response does not exceed 10 dB at the resonance frequency (approximately 200 kHz).

In the transfer function of the guard driver ($G(s)$, see eqn. 6), a first-order response of the guard driver is assumed. In practice, additional poles can cause peaking of the transfer function of the guard driver $G(s)$ which may lead to instability. The most common causes are:

- (i) Many operational amplifiers are not correctly compensated for use in buffer configurations (feedback = 1) and have a transfer function exceeding unity at high frequencies.
- (ii) The signal at the inverting input operational amplifiers is used as a signal for the shield drivers (Figs. 3 and 6). If a high-frequency common-mode signal is applied to a three-operational-amplifier instrumentation amplifier, the signal at the inverting inputs can be several dB larger in magnitude than the signal at the non-inverting inputs. This effect is caused by the input capacitances of the inverting inputs C_i , which are not negligible if large feedback resistors R_f are used. Compensation is possible by the addition of capacitors (C_f in Figs. 3 and 6) parallel to the feedback resistors R_f with a capacitance about equal to the input capacitance.

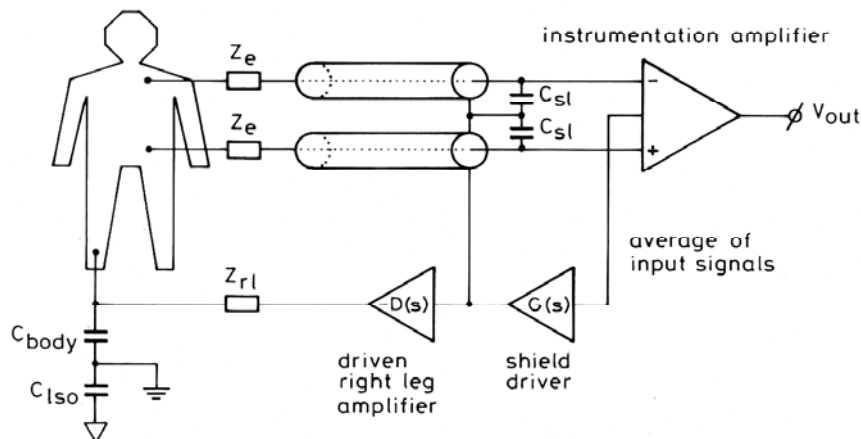

Fig. 8 Feedback loop formed by a driven right leg circuit. The guarding circuit of Fig. 6 is included in the loop

Driven right leg

The driven right leg loop with its relevant impedances and capacitances is shown in Fig. 8. It is assumed that a signal representing the average of the input signals (=common-mode voltage) is generated in the instrumentation amplifier (see for example Fig. 3). The average input signal is buffered by the shield driver with a frequency response $G(s)$ (eqn. 5) and subsequently used as an input signal for the driven right leg amplifier with response $-D(s)$. The loop is closed by the right leg electrode Z_{rl} , the capacitance between body and amplifier common (C_{body} in series with C_{iso}), the measurement electrodes Z_e and the input cables with shields C_{si} .

The stability of the circuit is evaluated by the analysis of the phase shift and amplification of the open-loop response. It is possible as well to evaluate the stability of the complete driven right leg circuit by calculating the poles of the closed-loop response. However, the equations derived in that way are not easily interpreted. Therefore, a different approach is followed here.

The main elements of the driven right leg loop are shown in the simplified diagram of Fig. 9. A negligible difference between the actual average input signal and input signal of the shield driver up to a very high frequency is assumed, the measurement system is not isolated and the electrode impedances are treated as resistances. The loop elements are: an RC section formed by the right leg electrode R_{rl} and the capacitance between body and amplifier common C_{body} , a second RC section formed by the resistance of the measurement electrode R_e and the capacitance of the shield C_{si} , the shield driver with a response $G(s)$, and finally the driven right leg amplifier with a response $-D(s)$ (an inverting amplifier).

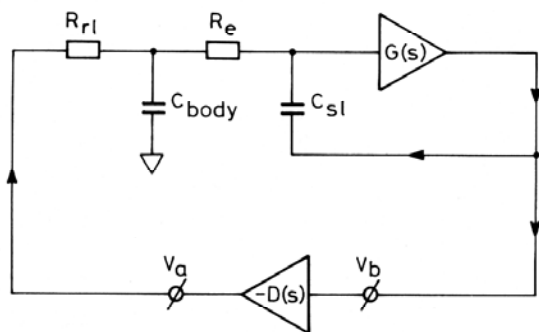

Fig. 9 Simplified diagram of the combined driven right leg and guarding circuits shown in Fig. 8. The stability margin of the circuit may be evaluated by calculating the phase shift between V_a and V_b .

A high inverting gain of the driven right leg amplifier is desirable because the reduction of common-mode voltage is proportional to the open-loop gain of the driven right leg circuit. However, a high gain may cause instability of the circuit because the circuit is stable only if the open-loop gain is smaller than unity at frequencies where the total phase shift in the loop is 180° . In designing a practical feedback circuit, a phase margin of at least 45° is commonly accepted, resulting in a maximum allowed phase shift of 135° at frequencies where the open-loop gain is larger than unity. This condition may be verified by calculating the phase shift of the open-loop response as a function of frequency.

A stable driven right leg circuit with high common-mode reduction at low frequencies can be obtained if an integrator is used as driven right leg amplifier (WINTER and WEBSTER, 1983). As an integrator already produces a phase shift of 90° , the phase shift caused by the other loop elements (the elements between V_a and V_b in Fig. 9) should not exceed 45° at frequencies where the open loop gain is larger than unity in order to retain a phase margin of 45° . The open-loop frequency response of the loop in

Fig. 9 from point V_a to point V_b is given by

$$L(s) = \frac{V_b}{V_a} = \frac{G(s)}{1 + R_{rl}C_{body}s + (1 - G(s)) \times \{C_{si}(R_e + R_{rl})s + R_{rl}C_{body}R_eC_{si}s^2\}} \quad (10)$$

where $G(s)$ is the response of the shield driver (eqn. 5).

If the low-pass cut-off frequency of the shield driver is high, $G(s)$ does not differ significantly from 0.99 up to a high frequency (A is 0.99 to reduce frequency response peaking) and eqn. 10 can be approximated by a first-order response with a pole at $s = -1/(R_{rl}C_{body})$. This single pole causes a 45° phase shift at approximately 27 kHz in a typical measurement situation (R_{rl} is 20 k Ω and C_{body} is 300 pF). To be certain that the circuit is stable even if electrode impedances are large, a gain of unity at 15 kHz was chosen for the response of the integrator in our applications (Figs. 3–5). The gain of the integrator is -300 at 50 Hz, offering a 50 dB reduction of common-mode voltage at this frequency.

The influence of the low-pass cutoff frequency of the shield driver follows from eqn. 10: if $G(s) = 1$, there is no influence of R_e and C_{si} . If $G(s)$ is not equal to 1, R_e and C_{si} influence $L(s)$ and the first-order approximation developed above does not suffice. In that case, the phase margin will reach 45° at a frequency lower than $f = 1/(2\pi R_{rl}C_{body})$ and the gain of the driven right leg circuit has to be reduced to maintain stability. However, if the low-pass cutoff frequency of the guarding circuit is chosen higher than approximately 1 MHz, it can be calculated (eqn. 10) that its influence upon the stability of the driven right leg circuit is negligible.

Authors' biographies



A. C. Metting van Rijn was born in 1959. In 1987 he received his degree in Physics from the University of Amsterdam. Currently he is with the Laboratory of Medical Physics & Informatics of the University of Amsterdam. His research interests centre on medical electronics and transducers. Since 1989 he has been working on a project for the development of miniature biomedical instrumentation, on a grant from the Technology Foundation (STW).



Abraham Peper was born in Amsterdam in 1939. After receiving his Ing. degree in Electrical Engineering in 1963, he joined the TNO Research Laboratory, Delft, where he was involved in the development of electret technology. Presently, he is working as a physicist at the Laboratory of Medical Physics of the University of Amsterdam. His current interests are signal analysis and the modelling of biological processes.

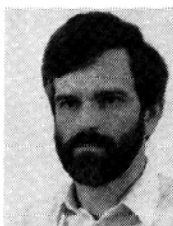

Cornelis A. Grimbergen (43) is a physicist at the Laboratory of Medical Physics of the University of Amsterdam. After receiving his Ir. degree in Electrical Engineering at the Delft University of Technology he was active in research in solid-state physics, resulting in a Ph.D. degree in 1977 from the University of Groningen. From 1977 he has been with the Medical Physics Laboratory, working in the fields of medical instrumentation, biomedical signal processing and biological system modelling.